

SOLAR POWERED E-BICYCLE

N.SRAVANI, G. HEMANTH KUMAR, T. NEERAJ KUMAR REDDY

Mrs. K. SWATHI, Assistant Professor, ECE Department

SAI SPURTHI INSTITUTE OF TECHNOLOGY, B. Gangaram, Sathupalli mandal,
Khammam District, Telangana.

Abstract: - As we all know the fuel prices especially the petrol is rising steadily day by day. Again the pollution due to vehicles in metro cities & urban areas is increasing continuously. To overcome these problems, an effort is being made to search some other alternative sources of energy for the vehicles. Again, it is also not affordable to purchase vehicles (mopeds, scooters or motorcycles) for all the class of society. Keeping this in mind, a search for some way to cater these economically poor people as well as to provide a solution for the environmental pollution was in progress. The solar assisted bicycle developed is driven by DC motor fitted in front or rear axle housing & operated by solar energy. The solar panels mounted on the carriage will charge the battery & which in turn drive the hub motor. When the bicycle is idle, the solar panel will charge the battery. This arrangement will replace the petrol engine, the gear box & the fuel tank in case of a two wheeler or a chain sprocket, chain & gear shifting arrangement of a conventional bicycle being used by most common man. [9] As a part of dissertation work, the solar assisted bicycle is fitted with a dc hub motor on front axle of a bicycle with power rating of 250W and with a travelling speed of around 25-30 kmph. It is provided with a pair of lead acid batteries of 35 Ah each, a photovoltaic solar panel with capacity of 20 watt, a voltage regulator of 24v 10 Amp, accelerator and motor controller of 24v 25Amp. There is also a provision for charging of the battery with 220-240V, AC wall outlet supply, in case of poor solar supply due to cloudy weather.

Keywords: Solar Assisted Bicycle (SAB), Hub Motor, Solar Panel, Motor Controller, Voltage Regulator.

I. INTRODUCTON

1.1 **General:** - This chapter will discuss about the main idea of this project and to get a larger picture on what is the problem in the current technologies, what that I want to achieve in this project and the area that will cover on this project. This chapter is divided into some categories that are project background to describe the reasons to do this project, problem statement to inform about the problem or weakness of the existing technology, objective to make sure what actually this project must achieve and scope of this project to specify what will be used in this project.

1.2 **Objective:-** To overcome the problem and the weakness, this project need to do some research and studying to develop better technology. To make it success there are several thing

that we need to know such as what will be the prime mover, how to stored it and the advantages of this new vehicle. In that case, these are the list of the objective to be conduct before continue to proceed on this project:

- ✓ To develop a vehicle that use renewable energy, environmentally friendly and cheap.
- ✓ To develop an electrical bicycle that can charge the battery when it is not in used.
- ✓ To develop low speed bicycle, but for a longer distance.



Fig 1 Output overview

II. LITERATURE REVIEW

As what had been mention earlier, there are several types of bicycle that can be categories that is paddle bicycle, motorized bicycle, and electric bicycle. The weakness of the bicycle make people do not like to used bicycle. First, paddle bicycle need a lot of energy to paddle the bicycle. The user will surely be tired after used the bicycle. This will not suitable for student to use to go to the class because they will be tired when they are in the class and will lost their concentration while hearing the lecture. Next, motorize bicycle that used fuel as it prime mover. The bicycle use fuel that is costly. As a student, their allowance is limited and only can be used for their study material and for their food to survive at the campus. Besides that, motorize bicycle will make pollution that can be very bad for our environment especially in this period that global warming happen to the earth. Lastly, electric bicycle that generate by battery can be only be sufficient for about an hour. The user needs to find power supply to.

III. PROJECT METHODOLOGY

3.1 Block diagram

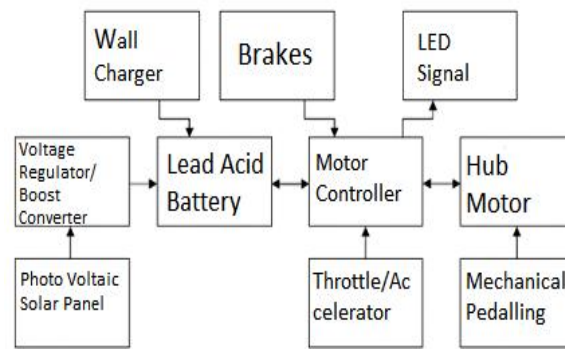

Fig 2 Basic block diagram of solar e bicycle

3.2 Hardware required

3.2.1 Hub Motor

The hub motor is a conventional Dc motor. The rotor (Fig.2) is outside the stator with the permanent magnets mounted on inside. The stator (Fig.3) is mounted and fixed onto the axle and the hub will be made to rotate by alternating currents supplied through batteries. Hub motor generates high torque at low speed, which is highly efficient and which doesn't need sprockets, brackets and drive chains. This means they are very reliable and have a long life. The main characteristic of Brushless DC Machines is that they may be controlled to give wide constant power speed ranges



Fig 3 Hub Motor

3.2.2 BLDC MOTOR

Brushless DC (BLDC) motors are synchronous motors consisting of armature windings on the stator permanent and magnets on the rotor. The stator of a BLDC motor consists of stacked steel laminations with windings placed in the slots and these stator winding can be arranged in two patterns i.e. a star pattern or delta pattern. The major difference between the two patterns is that the star pattern gives high torque at low RPM and the delta pattern gives low torque at low RPM. There are many advantages of BLDC motor such as better speed versus torque characteristics, high dynamic response, high efficiency, long operating life, noiseless operation, higher speed ranges

Features

Type of Motor	Hub motor
Design of Motor	BLDC (Brushless DC)
Power Rating	500W

3.2.3 Solar Cells/ Panels

As the title suggests the bicycle is operated by solar energy. The lead acid battery is charged with solar energy with the help of a solar cell. Solar cells convert the energy of sunlight directly into electricity through the use of the photovoltaic effect. The photovoltaic effect involves the creation of a voltage into an electro-magnetic radiation. The photoelectric and photovoltaic effects are related to sunlight, but are different in that electrons are ejected from a material’s surface upon exposure to radiation of sufficient energy in photoelectric, and generated electrons are transferred to different bands of valence to conduction within the material, resulting in the build-up of voltage between two

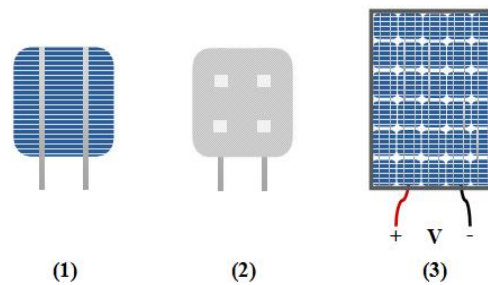

electrodes in photovoltaic.

Fig 4 Solar cells

3.2.4 SPV Charge Controller

It is essential to regulate the voltage output from the solar panel before it is supplied to the battery. A voltage regulator is a power converter with an output DC voltage greater than the input DC voltage. This is used to regulate an input voltage to a higher regulated voltage. The output of the solar panel is not always be stable due to fluctuations in intensity of sunlight, angular changes with respect to the direction of sunlight, as well as other environmental factors. This is the voltage regulator/Boost Converter comes into SAB. The output of the solar panel is the input of the boost converter, which then outputs into the battery for charging. Because the output of the solar panel will be varying constantly, we need a voltage regulator/boost converter that will take an input from a wide range of voltages and output a specific, constant voltage value. A voltage regulator/boost converter is a power converter that will take in a DC voltage and output a higher value DC voltage. Our voltage regulator/boost converter requires output of the solar panel, which can range from 0V to 27.2V, and output for charging of the battery. We were initially attracted to the SPV Instruments (Fig.5, Fig.6) Module because it has the characteristics of taking in an input range of 9.6V to 13.2V and outputting 24V at a maximum of 2-3 amps .This SPV has an area of 2.5 square inches so it is also small in size, which makes it very feasible to be placed.

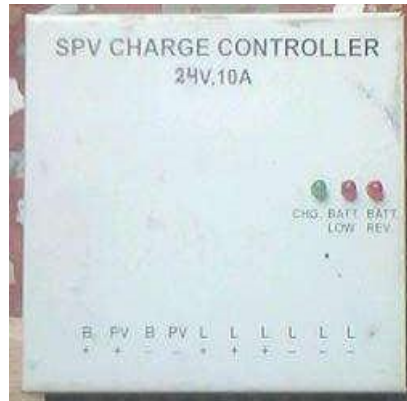

Fig 5 Solar charge controller unit

3.2.5 Lead acid batteries

Lead acid batteries (Fig.5) are one of the most popular types of battery in electronics. Although slightly lower in energy density than lithium metal, lead acid is safe, provided certain precautions are met when charging and discharging. This have a many advantages over other conventional types of batteries, the lead acid battery is the optimum choice for a solar assisted bicycle. Current supplied from battery indicates the flow of energy from the battery and is measured in amperes (or Amps) (Fig.5). The higher the current flow faster the battery will discharge. A battery is rated in ampere-hours (abbreviated Ah) and this is called the battery capacity. (Fig.5) This project revolves around supplying and utilizing energy within a high voltage battery (Fig.5). It demands for a battery with longer running hours, lighter weight with respect to its high output voltage and higher energy density. Among all the existing rechargeable battery systems, the lead acid cell technology is the most efficient and practical choice for the desired application. The battery chosen for this project was a high capacity lead acid battery pack designed specifically for vehicles. Plastic casing is provided to house the internal components of the battery.

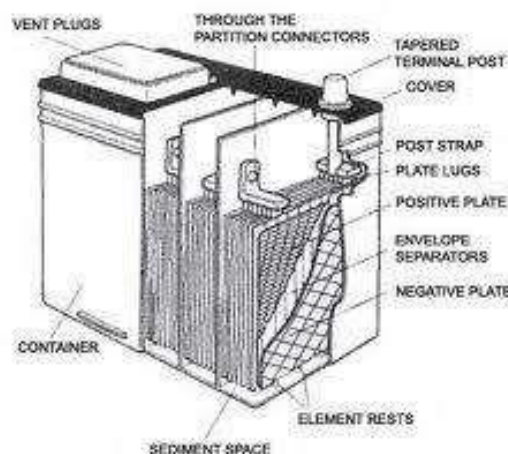

Fig .6. Lead Acid Battery

3.2.6 PIC CONTROLLER

Here we use PIC16F72 controller to control the electric bicycle system. In this

electric bicycle system some components are installed such as brushless dc motor, PIC controller, battery and dynamo, so here required to controller for controlling the different component of electric bicycle system. There are different functions of this controller such as under voltage protection, over current protection, control power supply, also to drive and control the Brushless dc motor. There are different signal were transmitted to pin of PIC controller to drive and control brushless dc motor, such as current detection signal, motor speed control signal, capacity detection system. In this PIC16F72 controller has 28 pins, 22 I/O pins that are user configurable on a pin-to-pin basis. There are 35 number of instruction in this PIC controller. The operating frequency is 20 MHz Also in this controller there are three I/O port are use such as PORTA, PORTB and PORTC and three Timers are use Timer0, Timer1 and Timer2. In this pin diagram RA1, RA4 and RA5 pin there are transmitted speed control, helping signal, current detection signal. The current detection signal use here because, if any heavy current situation electric bicycle is running at heavy load the current is increasing in motor. Then it will be damages winding of motor and component of motor. Here required current detection signal for controlling the current. Also there are under voltage protection is required because of avoid the low voltage supply, which is affect on electric bicycle running normally, then controller should be provide capacity checking. The voltage consists with resistance then it transmitted to PIC controller. If voltage supply signal transmitted to PIC controller then checking supply voltage.

3.2.7 Accelerometer/Throttle

The maximum speed of a bicycle is 30 kmph. It is required to vary the speed depending upon the road conditions & traffic. Therefore an accelerator or a throttle (Fig.13) is necessary. Throttle allows us to drive the motor from zero speed to full speed. The throttle is fitted on right side of the handle bar and is connected to controller. The throttle converts DC voltage from battery to an alternating voltage with variable amplitude and frequency that drives the hub motor at different speeds. It consists of MOSFET transistors and a small microprocessor. This throttle is technically referred to as a Hall Effect type. The throttle has three wires contains a black, red, and green. The supply voltage is via red and black wires and is usually around 4 volts. Green wire voltage increases as the throttle is turned.



Fig.7. Throttle

alternating voltage with variable amplitude and frequency that drive the hub motor at different speeds). It basically consists of MOSFET transistors and small microprocessor that

vary from detecting any malfunctions with the motor hall sensors, the throttle, to protect functions against excessive current and under-voltage, which are ideal for protecting the system.

Solar battery chargers are an inexpensive, environmentally friendly, and convenient way to make sure your batteries are always fully charged and ready to go all the time. The problem with charging a battery from a solarpanel is the SUN. It does not shine all the time and clouds get in the way. Our eyes adjust to the variations in the strength of the sun but a solar panel behaves differently. As soon as the sun loses its intensity, the output from a solar panel drops enormously. Not only does the output current fall, but the output voltage also decreases. Many of the solar panels drop to below the 13.6v needed to charge a 12v battery and as soon as this occurs, the charging current drops to ZERO. This means they become useless as soon as the brightness of the sun goes away

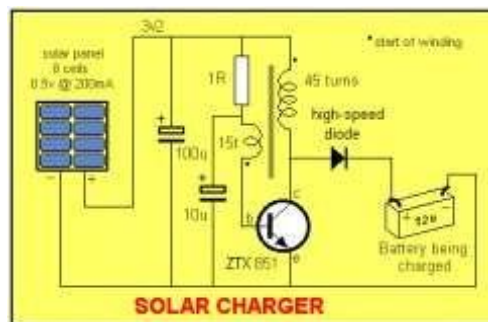

Fig 8. Solar Charger

IV. CONCLUSION AND FUTURE SCOPE

4.1 Conclusion

Solar assisted bicycle is modification of existing bicycle and driven by solar energy. It is suitable for both city and country roads, that are made of cement, asphalt, or mud. This bicycle is cheaper, simpler in construction & can be widely used for short distance travelling especially by school children, college students, office goers, villagers, postmen etc. It is very much suitable for young, aged, handicap people and caters the need of economically poor class of society. It can be operated throughout the year free of cost. The most important feature of this bicycle is that it does not consume valuable fossil fuels thereby saving crores of foreign currencies. It is ecofriendly & pollution free, as it does not have any emissions. Moreover it is noiseless and can be recharged with the AC adapter in case of emergency and cloudy weather. The operating cost per kilometer is minimal, around Rs.0.70/km. It can be driven by manual pedaling in case of any problem with the solar system. It has fewer components, can be easily mounted or dismounted, thus needs less maintenance. From a future energy system perspective, it is important to identify new ways of transport and generation of electricity and solar powered E-bike pools may just be such a case. E-bikes are an order of magnitude more energy efficient than car, bus or other heavy transport mode. Using a solar panel at 0.2-0.8 m² per E-bike has been shown to be enough to supply the early energy demand by the E-bike pool depending on simulated system usage (3-10.8 trips/(bike & day)). The computed area is smaller than the assumed maximum area at 3-3.8 m²/E-bike meaning that energy self-sufficiency on a yearly scale can be accomplished without running out of space. Using larger panel area than 0.2-0.8 m² per E-bike will for a grid-connected

system lead to net electric energy production.

4.2 Future Scope

This project is consists of two part that is hardware and software. The hardware will be the bicycle and the software is the program of the controller to control the operation of the bicycle. To be more specific about this project, there will be using several things that are:

- ✓ Use solar energy to recharge the battery.
- ✓ Use PIC Microcontroller for charging system.
- ✓ Use high torque motor to drive the bicycle.

REFERENCES

- [1] The Pandit G. Patil, Energy Systems Division, Argonne National Laboratory “Advanced Battery Technology for Electric Two-Wheelers” Journal of Energy Systems Division, Argonne National Laboratory June 2009.
- [2] Jean-Marc Timmermans¹, Julien Matheys, Philippe Lataire, Joeri Van Mierlo, Jan Cappelle² “A Comparative Study of 12 Electrically Assisted Bicycles” World Electric Vehicle Journal Vol. 3 - ISSN 2032-6653 - © 2009 AVERE.
- [3] Ahmad A. Pesaran and Tony Markel, Harshad S. Tataria, David Howell “Battery Requirements for Plug-In Hybrid Electric Vehicles – Analysis and Rationale” Conference Paper of National Renewable Energy Laboratory, USA NREL/CP-540-42240 July 2009.
- [4] Tony Markel, Michael Kuss, and Paul Denholm “Communication and Control of Electric Drive Vehicles Supporting Renewables” Conference Paper of Center for Transportation Technologies and Systems National Renewable Energy Laboratory, NREL/CP-540-46224 August 2009.
- [5] T. Markel, K. Bennion and W. Kramer, National Renewable Energy Laboratory & J. Bryan and J. Giedd Xcel Energy “Field Testing Plug-in Hybrid Electric Vehicles with Charge Control Technology in the Xcel Energy Territory.” Technical Report of National Renewable Energy Laboratory, NREL/TP-550-46345, August 2009.
- [6] T. Markel, K. Bennion and W. Kramer, National Renewable Energy Laboratory & J. Bryan and J. Giedd Xcel Energy “Field Testing Plug-in Hybrid Electric Vehicles with Charge Control Technology in the Xcel Energy Territory” Journal of International Conference on Renewable Energies and Power Quality (ICREPQ’11) Las Palmas de Gran Canaria (Spain), 13th to 15th April, 2011.
- [7] C. E. (Sandy) Thomas” Fuel Cell and Battery Electric Vehicles Compared” Journal of H2Gen Innovations, Inc., Alexandria, Virginia, 22304, USA.
- [8] Todd Litman, “Efficient Vehicles Versus Efficient Transportation “comparing transportation energy conservation strategies. Journal paper of Victoria Transport Policy Institute, 26 August 2009.